

Authenticity, values handed down and renewed, in the savoir-faire of the GARAVINI HOME collection, there are inspirations not only of style, there is rather a way of being, a style of seating that we decline in the form of a product.

Because the sofa is a language and we are its translators.

The important consolidated results in the tertiary sector naturally led to the choice to implement a product line that reflected the original stylistic and entrepreneurial spirit of the Company. Starting from the reason for its name, **GARAVINI HOME**. A reasoned and deliberate choice, to use HOME and not SOFA following the founder's surname, Vanni Garavini, precisely to determine the idea that for us, "the sofa is home". A collection of 18 products including sofas, armchairs and poufs with a dynamic, romantic, modern and constantly evolving taste. An intuitive and constant coherence of technical modularity and a highly qualified manufacturing capacity, interact with the interpretation of the new attitudes and new behaviors of living in an increasingly fast, elusive and technologized contemporaneity. Characteristics that are reflected in the communication of the product even before the product itself. From these reflections, we worked on the construction of a collection that is coherently eclectic and of a concrete design nature, therefore capable of being an ally of the concept of time and styles. Our models embrace the most diverse tastes without ever losing their course. Starting from a linear and modern style, passing through a soft maximalism, up to a japandi-oriented register and then turning towards a more nomadic expressive key such as that of boho-chic. All of them, strictly oriented towards the quality of the product performance and the recognisability of the seating of our sofas, a recognisability conceived, designed and built with kindness and determination. Intangible and material values that guide us, day after day, towards increasingly new and reliable interpretations of our idea of aesthetic, sensorial and functional comfort.

#### **GARAVINI HOME - SOFA LANGUAGE**

*Autenticità, valori tramandati e rinnovati, nel savoir-faire della collezione firmata GARAVINI HOME ci sono ispirazioni non solo di stile, c'è piuttosto un modo di essere, uno stile di seduta che decliniamo sotto forma di prodotto.*

*Perché il divano è un linguaggio e noi, i suoi traduttori.*

*Gli importanti risultati consolidati nel settore terziario, hanno condotto naturalmente alla scelta di implementare una linea di prodotto che raccontasse lo spirito stilistico e imprenditoriale originario dell'Azienda. Partendo dal perché del suo nome, **GARAVINI HOME**. Una scelta ragionata e voluta, quella di utilizzare a seguito del cognome del fondatore, Vanni Garavini, HOME e non SOFA, proprio a determinare l'idea che per noi, "il divano, è casa". Una collezione di 18 prodotti tra divani, poltrone e pouf dal gusto dinamico, romantico, moderno e perennemente in evoluzione. Una intuitiva e costante coerenza di componibilità tecnica e una capacità manifatturiera altamente qualificata, interagiscono con la lettura delle nuove attitudini e dei nuovi comportamenti dell'abitare una contemporaneità sempre più veloce, inafferrabile e tecnologizzata. Caratteristiche che si riflettono sulla comunicazione del prodotto ancor prima che sul prodotto stesso. Da queste riflessioni, abbiamo lavorato sulla costruzione di una collezione coerentemente eclettica e di natura progettuale concreta, capace pertanto di essere alleata del concetto di tempo e di stili. I nostri modelli abbracciamo i gusti più diversi senza mai perdere la loro rotta. Partendo da uno stile lineare e moderno, passando attraverso un massimalismo soft, fino ad arrivare ad un registro orientato al japandi, per poi volgere verso una chiave espressiva più nomade come quella del boho-chic. Tutto rigorosamente orientato alla qualità della performance del prodotto e della riconoscibilità di seduta dei nostri divani, una riconoscibilità pensata, progettata e costruita con gentilezza e determinazione. Valori immateriali e materiali che ci guidano, giorno dopo giorno, verso sempre più nuove e affidabili interpretazioni della nostra idea di comfort estetico, sensoriale e funzionale.*

#### **GARAVINI HOME - SOFA LANGUAGE**

Authenticité, valeurs transmises et renouvelées, dans le savoir-faire de la collection GARAVINI HOME, il y a des inspirations non seulement de style, il y a plutôt une manière d'être, un style d'assise que l'on décline sous forme de produit. Parce que le canapé est une langue et nous en sommes les traducteurs. Les importants résultats consolidés dans le secteur tertiaire ont naturellement conduit au choix de mettre en œuvre une ligne de produits qui reflète l'esprit stylistique et entrepreneurial original de l'entreprise. À commencer par la raison de son nom, **GARAVINI HOME**. Un choix raisonné et délibéré, d'utiliser HOME et non SOFA d'après le nom du fondateur, Vanni Garavini, précisément pour déterminer l'idée que pour nous, « le canapé, c'est la maison ». Une collection de 18 produits comprenant des canapés, des fauteuils et des poufs au goût dynamique, romantique, moderne et en constante évolution. Une cohérence intuitive et constante de modularité technique et une capacité de fabrication hautement qualifiée, interagissent avec l'interprétation des nouvelles attitudes et des nouveaux comportements de vie dans une contemporanéité de plus en plus rapide, insaisissable et technologisée. Des caractéristiques qui se reflètent dans la communication du produit avant le produit lui-même. A partir de ces réflexions, nous avons travaillé à la construction d'une collection cohérente, éclectique et de nature concrète, donc capable d'être alliée des événements et styles actuels. Nos modèles embrassent les goûts les plus divers sans jamais perdre leur cap. En partant d'un style linéaire et moderne, en passant par un maximalisme doux, jusqu'à un registre orienté au japandi, pour se tourner ensuite vers une touche expressive plus nomade comme celle du boho-chic. Le tout strictement orienté vers la qualité de la performance du produit et la reconnaissabilité de l'assise de nos canapés, une reconnaissabilité conçue et construite avec gentillesse et détermination. Des valeurs immatérielles et matérielles qui nous guident, jour après jour, vers des interprétations de plus en plus nouvelles et fiables de notre idée du confort esthétique, sensoriel et fonctionnel.

#### **GARAVINI HOME - SOFA LANGUAGE**



Garavini S.r.l.  
info@garavinihome.it - www.garavinihome.it  
Forlì . Italy . Europe

## sofas



**ASANA**  
428



**BROWNIE**  
427



**FIL ROUGE**  
355



**FUSION**  
411



**GLAM**  
407



**LUST**  
365



**QUEEN BEE**  
410



**SIDECAR**  
429



**TAILOR**  
373



**YOGA**  
423

## armchairs



**AVOCADO**  
368



**BLUEBERRY**  
416



**LADY G.**  
366



**PALOMA**  
417

ASANA 428





# ASANA 428

Prodotto interamente sfoderabile.  
Disponibile solo in tessuto.

Entirely removable cover.  
Available only in fabric.

**STRUTTURA:** legno e multistrato, molleggio sedute con cinghie elastiche e molle insacchettate.  
**CUSCINI DI SEDUTA:** poliuretano 30kg/m<sup>3</sup> + toppei di sostegno seduta luxury comfort 22kg/m<sup>3</sup>.  
**CUSCINI SCHIENALE:** 18kg/m<sup>3</sup> soft.  
**BRACCIOLO:** poliuretano 30kg/m<sup>3</sup> + falda.  
**PIEDI:** perimetrali in legno.

**STRUCTURE:** wood and plywood, seat suspension with elastic straps and pocket springs.  
**SEAT CUSHIONS:** polyurethane 30kg/m<sup>3</sup> + luxury comfort seat support toppei 22kg/m<sup>3</sup>.  
**BACK CUSHIONS:** 18kg/m<sup>3</sup> soft.  
**ARMREST:** polyurethane 30kg/m<sup>3</sup> + padding.  
**FEET:** perimeter wooden feet.

DESGNI IN SCALA 1:8 - MISURE ESPRESSE IN CM/POLLICI

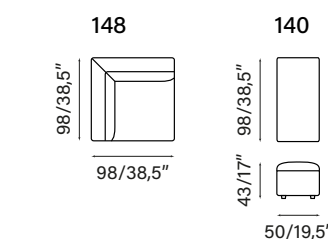
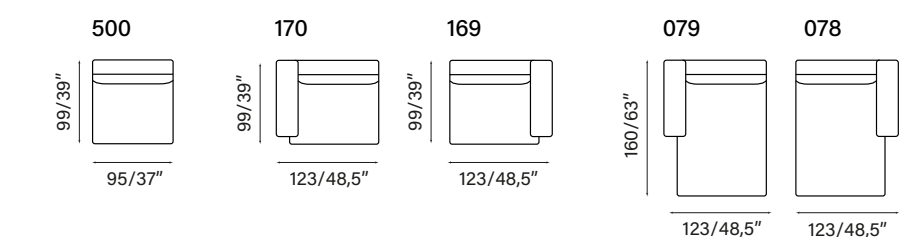
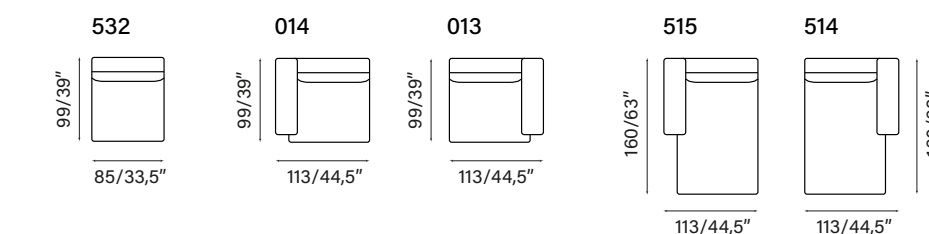
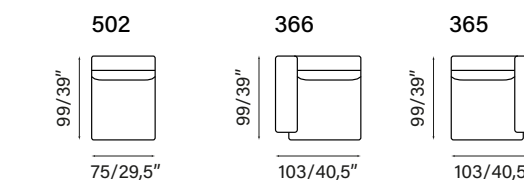
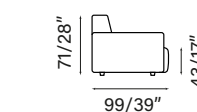

# ASANA 428

# BROWNIE 427





## BROWNIE 427

Inserimento letto non possibile.  
Prodotto interamente sfoderabile. Disponibile solo in tessuto. Meccanismo schienale manuale.  
**OPZIONALE:** meccanismo pediera elettrica.  
**TOP:** pannello in melaminico.

Folding bed not available.  
Entirely removable cover. Available only in fabric.  
Manual backrest mechanism.  
**OPTION:** electric footrest mechanism.  
**TOP:** melamine panel.

**STRUTTURA:** legno e multistrato, molleggio sedute con cinghie elastiche.  
**CUSCINI DI SEDUTA:** poliuretano 30kg/m<sup>3</sup> + fiocco.  
**CUSCINI SCHIENALE:** fiocco.  
**BRACCIOLO:** poliuretano 30kg/m<sup>3</sup> + fiocco, reversibile e autonomo.  
**PIEDI:** piedi perimetrali in legno.

**STRUCTURE:** wood and plywood, seat springing with elastic straps.  
**SEAT CUSHIONS:** 30kg/m<sup>3</sup> polyurethane + staple.  
**BACK CUSHIONS:** staple.  
**ARMREST:** 30kg/m<sup>3</sup> polyurethane + staple, reversible and autonomous armrest.  
**FEET:** wooden perimeter feet.

DISEGNI IN SCALA 1:8 - MISURE ESPRESSE IN CM/POLLICI

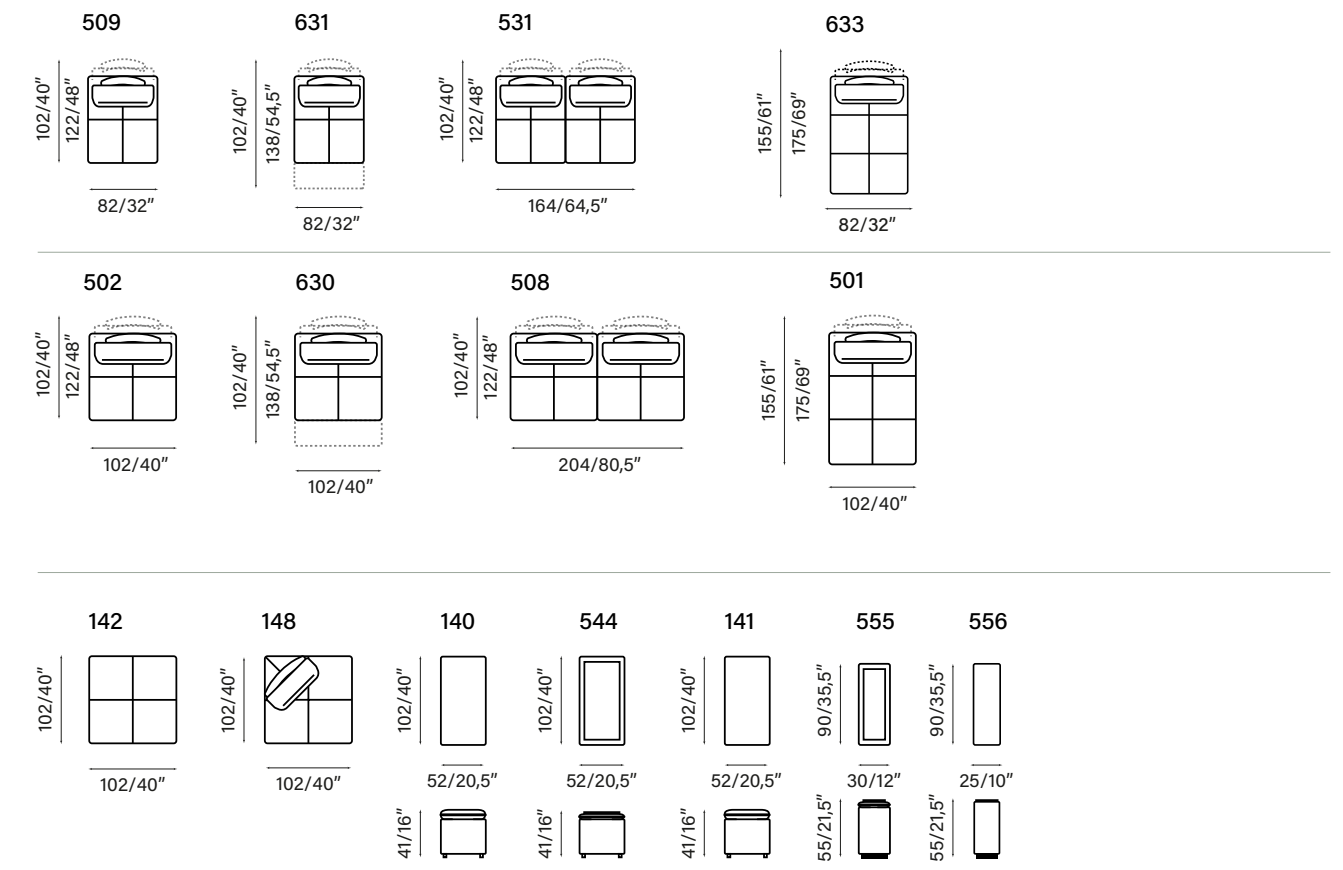
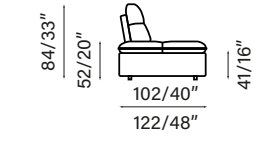

## BROWNIE 427

**NOTE - ATTENZIONE:** l'utilizzo di elementi di gruppi diversi determina una larghezza di disegno e seduta differente.  
**NOTES - WARNING:** mixture of elements belonging to different groups will cause different pattern and seat widths.

FIL ROUGE 355





## FIL ROUGE 355

Prodotto non sfoderabile. Disponibile in pelle e in tessuto. Inserimento letto non possibile.

**FILETTO SCOCCA:** sempre abbinato a fusto o cuscineria.

**FILETTO CUSCINERIA:** sempre abbinato a fusto o cuscineria.

**STRUTTURA:** legno e multistrato, molleggio sedute con cinghie elastiche.

**CUSCINI DI SEDUTA:** poliuretano 30 Kg/m<sup>3</sup> rivestiti in falda.

**CUSCINI SCHIENALE:** in poliuretano 25 Kg/m<sup>3</sup> rivestiti in falda.

**CUSCINI POGGIARENI:** in misto piuma.

**PIEDI:** in legno altezza 4 cm.

Not removable cover. Available in both leather and fabric. Folding bed not available.

**FRAME PIPING:** always matched with frame or cuscineria.

**CUSHION PIPING:** always matched with frame or cushions.

**STRUCTURE:** hard wood frame, seat suspensions in reinforced elastic webbing.

**SEAT CUSHIONS:** in polyurethane 30 Kg/m<sup>3</sup> covered with wadding.

**BACK CUSHIONS:** in polyurethane 25 Kg/m<sup>3</sup> covered with wadding.

**BACKREST CUSHIONS:** in goose down and polyester wadding.

**FEET:** wood legs height 4 cm - 1,6"

DISEGNI IN SCALA 1:8 - MISURE ESPRESSE IN CM/POLLICI

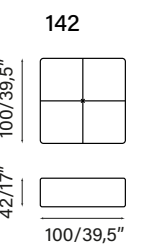
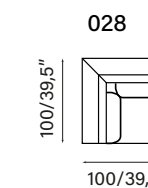
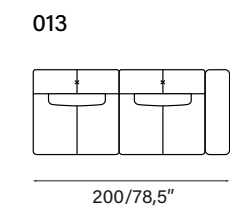
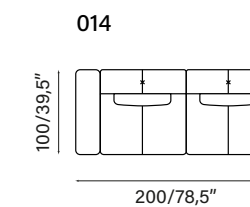
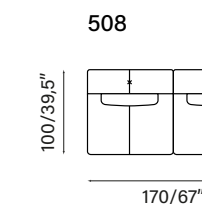
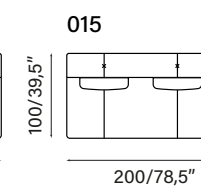
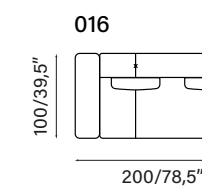
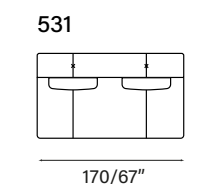
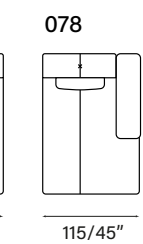
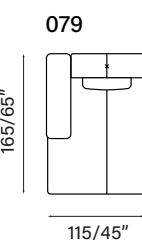
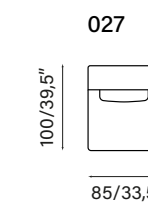
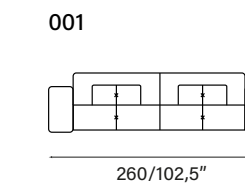
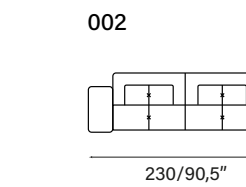
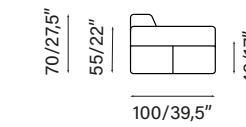

## FIL ROUGE 355



FUSION 411





## FUSION 411

Prodotto interamente sfoderabile.  
Disponibile solo in tessuto.

Entirely removable cover.  
Available only in fabric.

**STRUTTURA:** compensato con dettagli in abete.

**FRAME:** plywood with fir details.

**SOSPENSIONE:** molle del materasso e cinghie.

**SUSPENSION:** mattress springs plus straps.

**CUSCINI DI SEDUTA:** in poliuretano rivestito di ovatta.

**SITTING CUSHIONS:** in polyurethane covered with wadding.

**CUSCINI SCHIENALE:** sfoderabili in poliuretano 25 kg/m<sup>3</sup> rivestito in ovatta, costruiti con una solida base antiscivolo.

**BACK CUSHIONS:** removable covers made of 25 kg/m<sup>3</sup> polyurethane covered with wadding, constructed with a solid non-slip base.

**PIEDI:** in plexiglass, illuminati a batteria o con cavo elettrico. Disponibile anche la versione con piedini in metallo.

**FEET:** plexiglass, enlited battery powered or by electric cable. Also available a metal feet version.

DISEGNI IN SCALA 1:8 - MISURE ESPRESSE IN CM/POLLICI

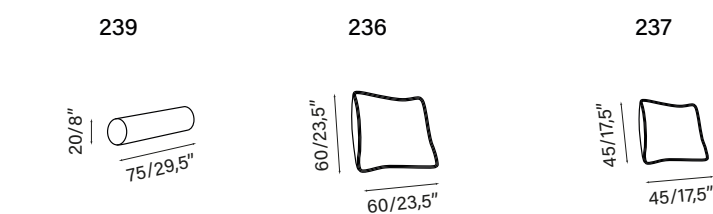
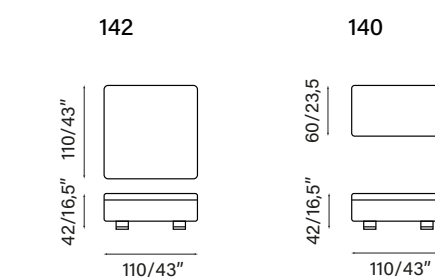
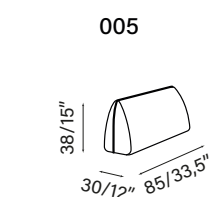
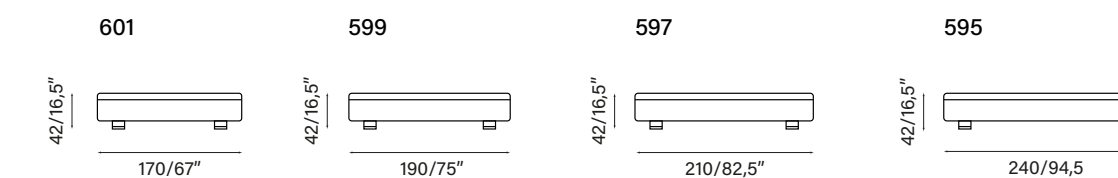

## FUSION 411

GLAM 407





# GLAM 407

Prodotto interamente sfoderabile. Disponibile solo in tessuto. Meccanismo seduta manuale, a slitta.

Entirely removable cover. Available only in fabric. Manual, slide seat mechanism.

**STRUTTURA:** legno e multistrato, molleggio sedute con cinghie elastiche.

**STRUCTURE:** wood and plywood, seat suspension with elastic straps.

**CUSCINI DI SEDUTA:** poliuretano 30Kg/m<sup>3</sup> rivestito in falda.

**SEAT CUSHIONS:** 30Kg/m<sup>3</sup> polyurethane covered with wadding.

**CUSCINI SCHIENALE:** misto piuma.

**BACKREST CUSHIONS:** mixed feather.

**PIEDI:** piedi in metallo.

**FEET:** metal feet.

DISEGNI IN SCALA 1:8 - MISURE ESPRESSE IN CM/POLLICI

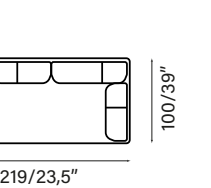
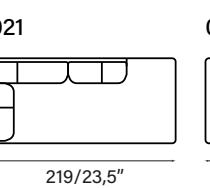
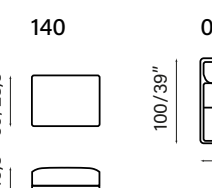
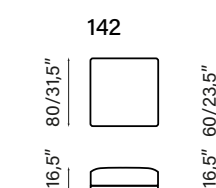
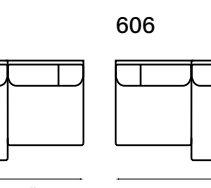
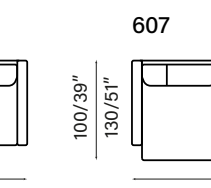
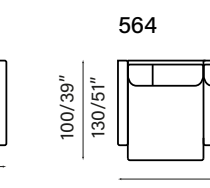
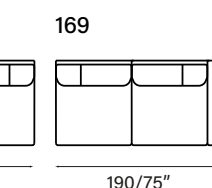
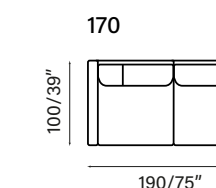
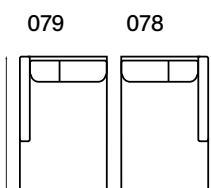
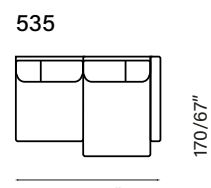
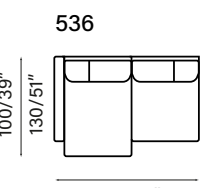
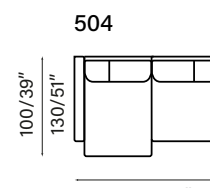
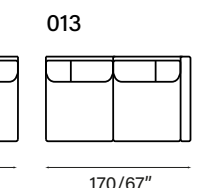
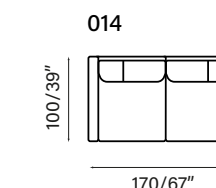
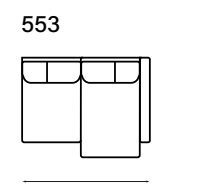
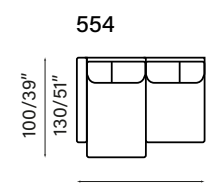
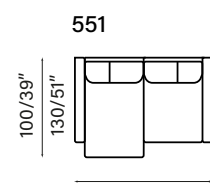
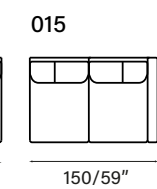
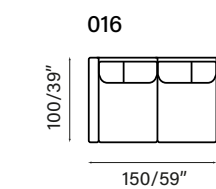
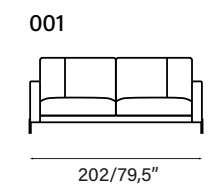
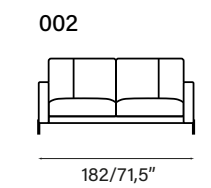
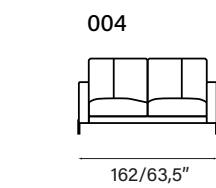
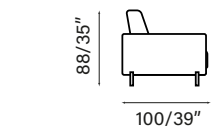

# GLAM 407



LUST 365





## LUST 365

Prodotto non sfoderabile. Disponibile solo in tessuto.  
Inserimento letto non possibile.  
**TAVOLINO:** struttura in metallo verniciato e pannello in melamminico.

**STRUTTURA:** legno e multistrato, molleggio sedute con cinghie elastiche.

**CUSCINI DI SEDUTA:** poliuretano 30kg/m3 rivestiti in falda.

**CUSCINI SCHIENALE:** in misto piuma.  
**PIEDI:** in legno.

Not removable cover. Available only in fabric.  
Folding bed not available.  
**COFFEE TABLE** painted metal frame and melamine table top.

**STRUCTURE:** wood and plywood, seat sprung with elastic straps.

**SEAT CUSHIONS:** polyurethane 30kg/m3 covered with wadding.

**BACK CUSHIONS:** in goose down and polyester wadding.

**FEET:** wood legs.

DISEGNI IN SCALA 1:8 - MISURE ESPRESSE IN CM/POLLICI

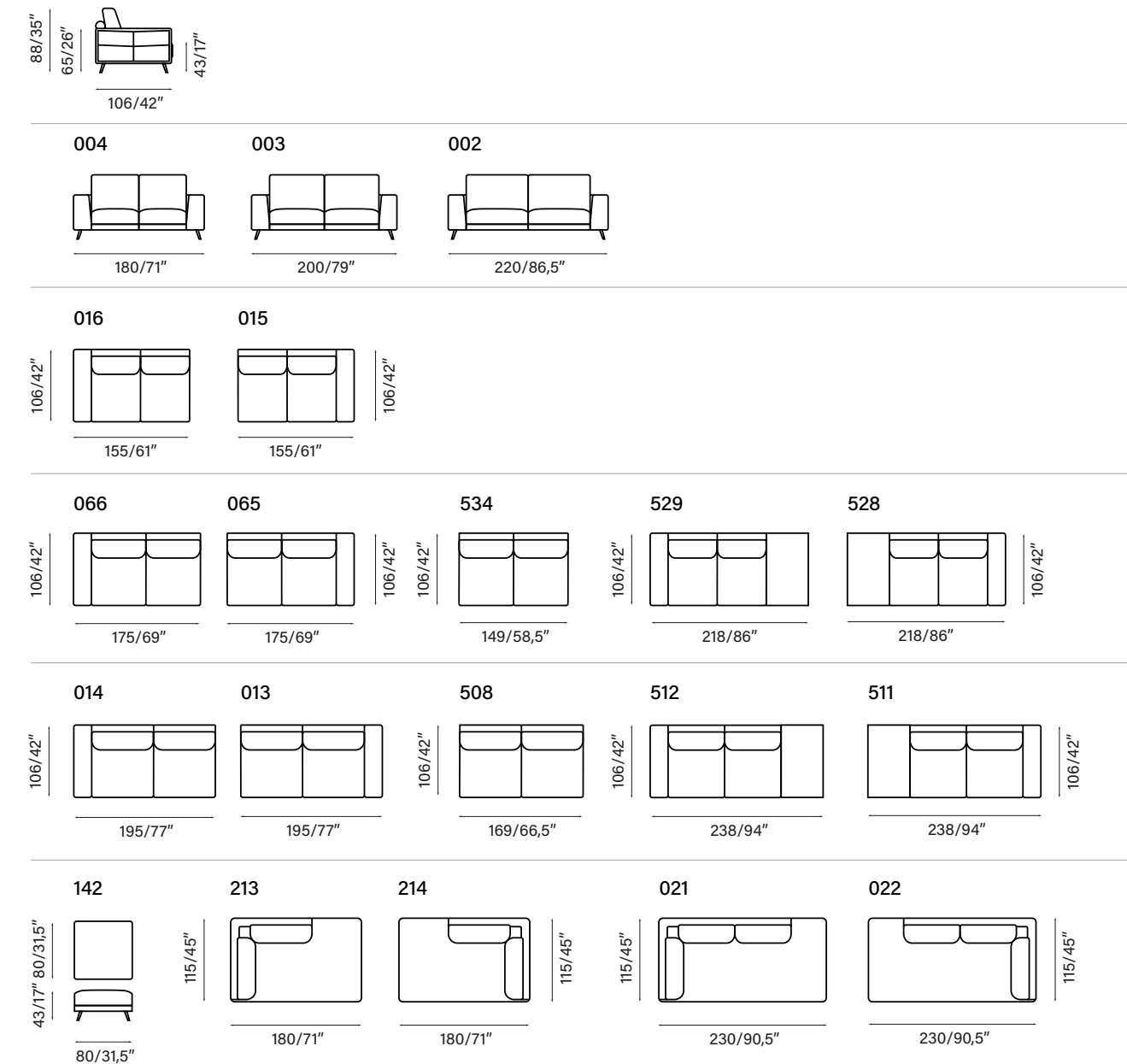

## LUST 365

**NOTE - ATTENZIONE:** l'utilizzo di elementi di gruppi diversi determina una larghezza di disegno e seduta differente. Negli elementi cod. 529, 528, 512, 511 è inserito un tavolino con struttura in metallo verniciato e pannello in melamminico con la funzione di vassoio e il vano dove è riposto il tavolino diventa contenitore.

**NOTES - WARNING:** mixture of elements belonging to different groups will cause different pattern and seat widths. Items cod. 529, 528, 512, 511 contain a painted metal frame and a melamine table top, serving as a tray and where a storage unit is so placed.

QUEEN BEE 410





## QUEEN BEE 410

Prodotto interamente sfoderabile.  
Disponibile solo in tessuto.

Entirely removable cover.  
Available only in fabric.

**STRUTTURA:** compensato con particolari in abete.

**STRUCTURE:** plywood with fir details.

**SOSPENSIONE:** molleggio sedute con cinghie elastiche.

**SUSPENSION:** seat springing with elastic straps.

**CUSCINI DISEDUTA:** in poliuretano 35-30 Kg/m<sup>3</sup> rivestiti in ovatta.

**SEAT CUSHIONS:** in polyurethane 35-30 Kg/m<sup>3</sup> covered with wadding.

**CUSCINI SCHIENALE:** in poliuretano 21 Kg/m<sup>3</sup> rivestito in ovatta.

**BACK CUSHIONS:** in polyurethane 21 Kg/m<sup>3</sup> covered with wadding.

**BRACCIOLO:** opzionale e reversibile, in legno duro e metallo verniciato, in poliuretano 25 Kg/m<sup>3</sup> rivestito in ovatta.

**ARMREST:** optional and reversible, hard wood and painted metal, polyurethane 25 Kg/m<sup>3</sup> covered with wadding.

**PIEDI:** in plastica antiscivolo.

**FEET:** plastic non-slip.

DISEGNI IN SCALA 1:8 - MISURE ESPRESSE IN CM/POLLICI

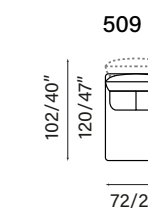
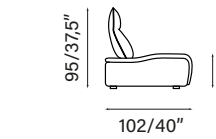

509

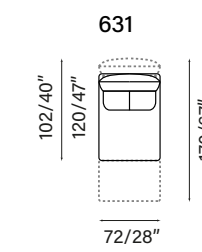

631

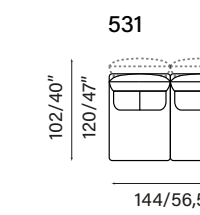

531

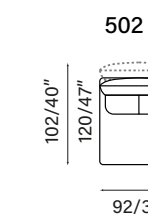

502

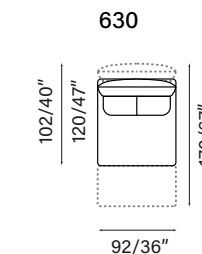

630

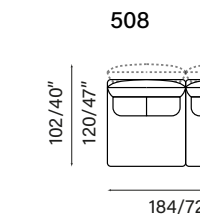

508

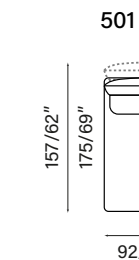

501

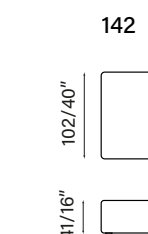

142

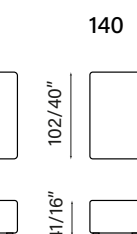

140

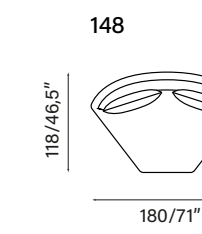

148

## QUEEN BEE 410



SIDECAR 429





TAILOR 373





## TAILOR 373

Prodotto non sfoderabile. Disponibile in pelle e in tessuto.

**STRUTTURA:** legno e multistrato, molleggio sedute con cinghie elastiche e molle insacchettate.

**CUSCINI DI SEDUTA:** poliuretano 30kg/m<sup>3</sup> rivestiti in falda.

**CUSCINI SCHIENALE:** poliuretano 21kg/m<sup>3</sup> rivestiti in falda.

**BRACCIOLO:** poliuretano 25kg/m<sup>3</sup> rivestito in falda.

**CUSCINI POGGIARENI:** in fiocco.

**PIEDI:** in plexiglass.

Not removable cover. Available in both leather and fabric.

**STRUCTURE:** hard wood frame, seat suspensions in reinforced elastic webbing.

**SEAT CUSHIONS:** polyurethane 30kg/m<sup>3</sup> covered with wadding.

**BACK CUSHIONS:** polyurethane 21kg/m<sup>3</sup> covered with wadding.

**ARMREST:** cushions in polyurethane.

**BACKREST CUSHIONS:** in polyester wadding.

**FEET:** plexiglas legs.

DISEGNI IN SCALA 1:8 - MISURE ESPRESSE IN CM/POLLICI

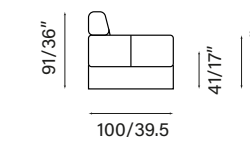

006

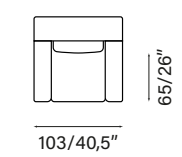

004

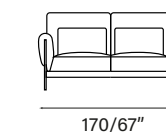

002

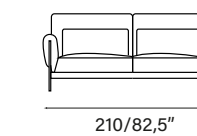

001

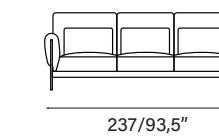

## TAILOR 373

YOGA 423





## YOGA 423

Prodotto interamente sfoderabile. Disponibile solo in tessuto. Meccanismo seduta manuale, a slitta. Meccanismo poggiatesta manuale.

Entirely removable cover. Available only in fabric. Manual, slide seat mechanism. Manual headrest mechanism.

**STRUTTURA:** legno abete con particolari in agglomerato, molleggio sedute con cinghie elastiche.

**STRUCTURE:** fir wood with agglomerate details, seat suspension with elastic straps.

**CUSCINI DI SEDUTA:** poliuretano 30Kg/m<sup>3</sup>.

**SEAT CUSHIONS:** 30Kg/m<sup>3</sup> polyurethane covered with wadding and dacron.

**POGGIARENI:** poliuretano 21 Kg/m<sup>3</sup> rivestito con falda e dacron.

**BACKREST CUSHIONS:** 21Kg/m<sup>3</sup> polyurethane covered with wadding and dacron.

**POGGIATESTA:** poliuretano 18 Kg/m<sup>3</sup> rivestito in falda e dacron.

**HEADREST:** 18Kg/m<sup>3</sup> polyurethane covered with wadding and dacron.

**PIEDI:** piedi a cono in legno o variante barra in metallo.

**FEET:** wooden cone feet or metal bar variant.

DISEGNI IN SCALA 1:8 - MISURE ESPRESSE IN CM/POLLICI

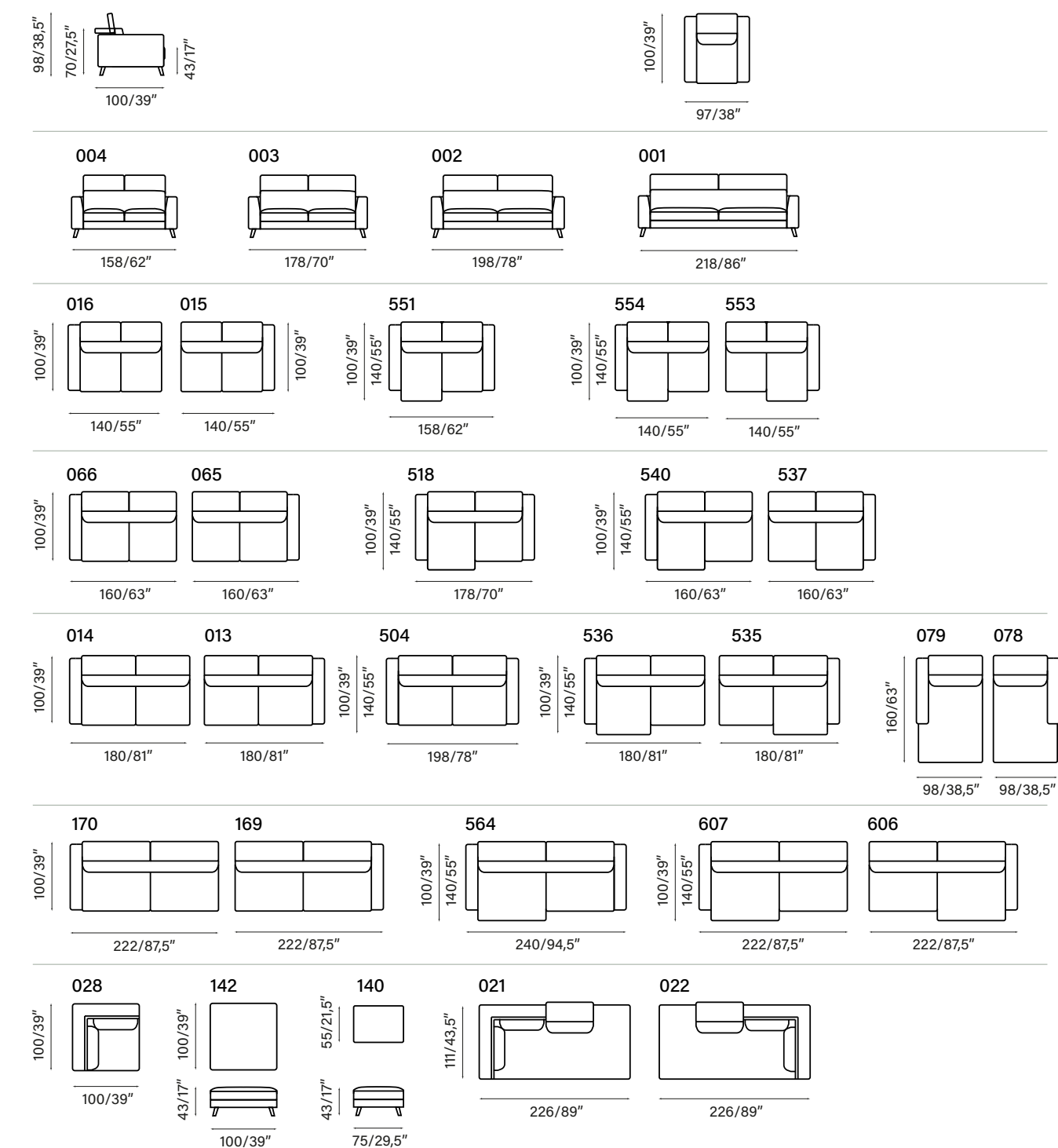

## YOGA 423





## AVOCADO 368

Prodotto non sfoderabile. Disponibile in pelle e in tessuto.

**STRUTTURA:** legno e multistrato, molleggio seduta con cinghie elastiche.

**CUSCINI SEDUTA:** poliuretano 30kg/m<sup>3</sup> rivestiti in falda.

**CUSCINI SCHIENALE:** poliuretano 25kg/m<sup>3</sup> rivestiti in falda.

**PIEDI:** legno massello col. naturale, wengè o noce.

Not removable cover. Available in both leather and fabric.

**STRUCTURE:** hard wood frame, seat suspensions in reinforced elastic webbing.

**SEAT CUSHIONS:** in polyurethane 30kg/m<sup>3</sup> covered with wadding.

**BACK CUSHIONS:** in polyurethane 25Kg/m<sup>3</sup> covered with wadding.

**FEET:** hardwood foot in natural or wengè or walnut colour.

DISEGNI IN SCALA 1:8 - MISURE ESPRESSE IN CM/POLLICI



006



## AVOCADO 368

AVOCADO 368







## BLUEBERRY 416

Prodotto interamente sfoderabile.  
Disponibile in pelle e in tessuto.

Entirely removable cover.  
Available in both leather and fabric.

**STRUTTURA:** in multistrato.  
**CUSCINI DI SEDUTA:** in poliuretano 35 Kg/m<sup>3</sup>  
rivestito in ovatta.  
**CUSCINI SCHIENALE:** misto piuma.  
**PIEDI:** metallo verniciato.

**STRUCTURE:** multilayer.  
**SEAT CUSHIONS:** in polyurethane 35 Kg/m<sup>3</sup>  
covered with wadding.  
**BACK CUSHIONS:** mixed down.  
**FEET:** painted metal.

DISEGNI IN SCALA 1:8 - MISURE ESPRESSE IN CM/POLLICI

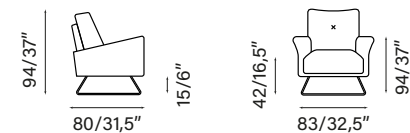

006



BLUEBERRY 416

BLUEBERRY 416

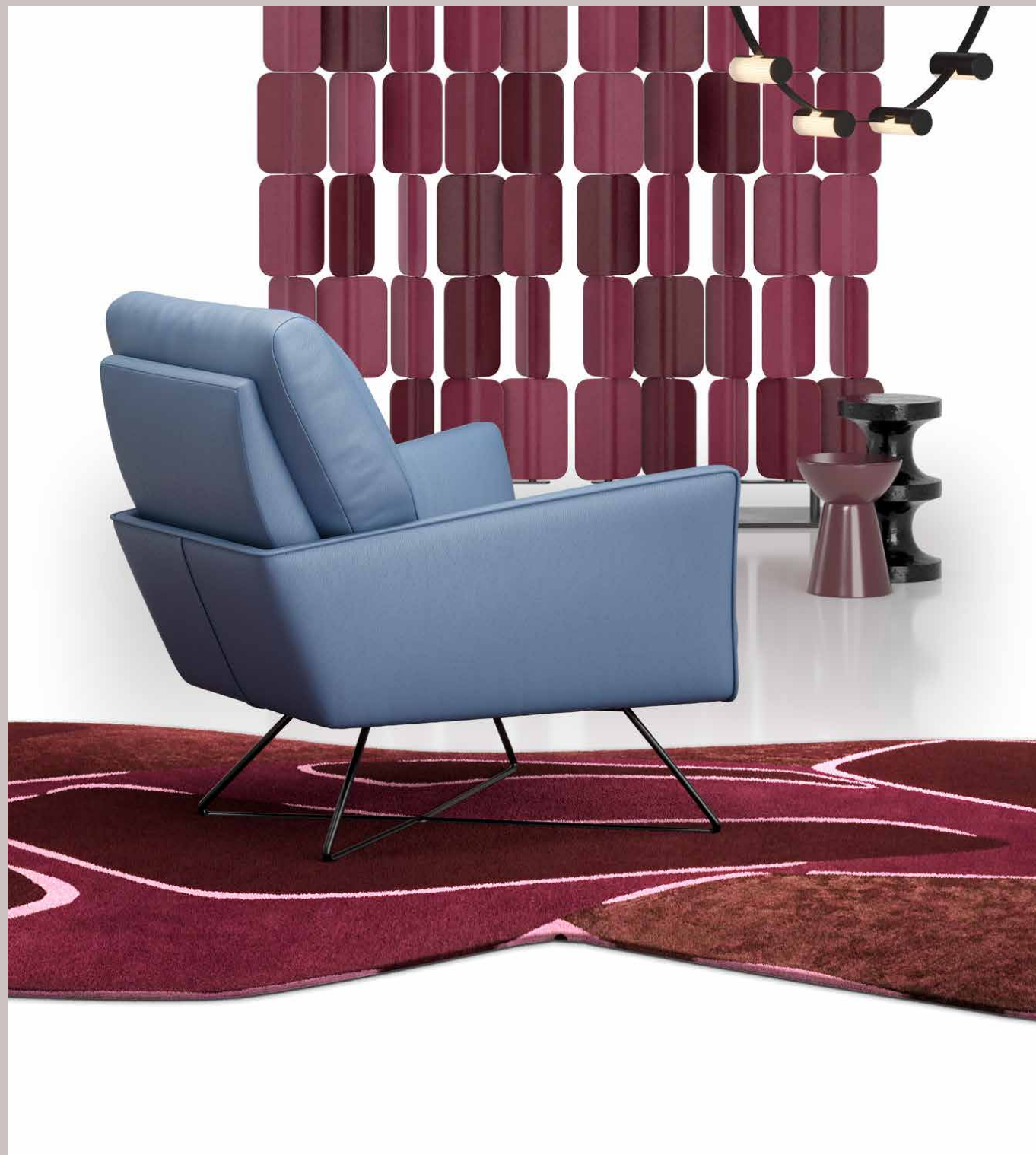



## LADY G 366

Prodotto non sfoderabile. Disponibile in pelle e in tessuto.

**STRUTTURA:** legno e multistrato, molleggio sedute con cinghie elastiche.

**CUSCINI DI SEDUTA:** in poliuretano 30kg/m<sup>3</sup> rivestiti in falda.

**CUSCINI SCHIENALE:** in poliuretano 25kg/m<sup>3</sup> rivestiti in falda.

**PIEDI:** in metallo verniciato nero.

Not removable cover. Available in both leather and fabric.

**STRUCTURE:** wood and plywood, seat sprung with elastic straps.

**SEAT CUSHIONS:** polyurethane 30kg/m<sup>3</sup> covered with wadding.

**BACK CUSHIONS:** polyurethane 25kg/m<sup>3</sup> covered with wadding.

**FEET:** black painted metal foot.

DISEGNI IN SCALA 1:8 - MISURE ESPRESSE IN CM/POLLICI

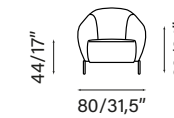
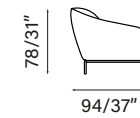

366



LADY G. 366



## PALOMA 417

Prodotto non sfoderabile. Disponibile in pelle e in tessuto.

**STRUTTURA:** legno e multistrato, molleggio seduta con cinghie elastiche.

**CUSCINI DI SEDUTA:** poliuretano 30kg/m<sup>3</sup> rivestiti in falda.

**CUSCINI SCHIENALE:** poliuretano 25kg/m<sup>3</sup> rivestiti in falda.

**PIEDI:** in metallo cromato.

Not removable cover. Available in both leather and fabric.

**STRUCTURE:** hard wood frame, seat suspensions in reinforced elastic webbing.

**SEAT CUSHIONS:** polyurethane 30kg/m<sup>3</sup> covered with wadding.

**BACK CUSHIONS:** polyurethane 25Kg/m<sup>3</sup> covered with wadding.

**FEET:** chrome metal base.

DISEGNI IN SCALA 1:8 - MISURE ESPRESSE IN CM/POLLICI

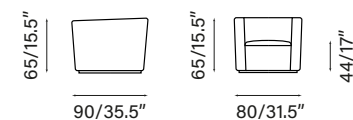

367

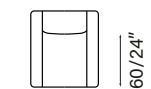

PALOMA 417

ad: maria sole perfido . rendering: studio fotograf . grafica: felgioni.it . stampa: flograt artti grafiche

#### INSPIRED, CREATIVE, FUNCTIONAL

GRVN is an emerging line of contemporary sofas. Industrial spin-off of GARAVINI HOME an Italian generative industry specialized in the high prototyping and production of upholstered furniture for some of the most well-known European distribution chains.

Strengthened by the many years of experience of the GARAVINI HOME Group, GRVN can count on a highly methodologized supply chain. Garavini Vanni, hence the acronym GRVN, has been able to enhance and circularly optimize all production processes: from integrated prototyping, to extensive procurement, up to widespread production and oriented distribution, landing on sales channels with a dedicated approach to the different types of B2B Customers.

The philosophy of GRVN has its roots in the idea of living in an increasingly conscious way, happily aware of being a set of contradictions in a world with a high speed of change. The constant analysis of new behaviors and new habits of living spaces is an active part of our "stylistic blend". To focus on shared well-being, we believe we should move towards new forms of "product optimism", raising the Customer's awareness in a depth knowledge of the sector in which we operate.

Taking inspiration from the concept of "opposites attract", the models we have designed, represent a balanced mix of sumptuous lines and delicately tailored technical definitions. The materials that make up our design come together in a way that is sometimes unexpected but always convincing. GRVN is ethics and aesthetics as a style statement. Because with our "optimistic products", we wish to communicate the importance of surrounding ourselves and living with objects that tell the beauty of each phase that determined their birth.

GRVN  
WE DESIGN, WE CREATE, YOU ENJOY  
AND NOW, "RELAX & SIT IT EASY..."

#### INSPIRED, CREATIVE, FUNCTIONAL

GRVN è una linea emergente di divani contemporanei. Spin-off industriale di GARAVINI HOME, Industria italiana di tipo generativo, specializzata nell'alta prototipazione e produzione di mobili imbottiti per alcune tra le più note catene di distribuzione europee.

Forte della pluriennale esperienza del Gruppo GARAVINI HOME, GRVN può contare su una supply chain altamente metodologizzata.

Garavini Vanni, da qui l'acronimo GRVN, è stato in grado di valorizzare e ottimizzare circolarmente tutti i processi produttivi: dalla prototipazione integrata, all'approvvigionamento estensivo, fino alla produzione diffusa e ad una distribuzione orientata, atterrando sui canali di vendita con un approccio dedicato alle diverse tipologie di Cliente B2B.

La filosofia di Marchio GRVN, affonda le sue radici nell'idea di vivere in modo sempre più consapevole, felicemente consci di essere un insieme di contraddizioni in un mondo ad alta velocità di cambiamento.

L'analisi costante dei nuovi comportamenti e delle nuove abitudini del vivere gli spazi, è parte attiva del nostro "blend stilistico".

Per puntare sul benessere condiviso, crediamo ci si dovrebbe orientare verso nuove forme di "ottimismo del prodotto", sensibilizzando il Cliente all'approfondimento e alla conoscenza del settore nel quale operiamo.

Traendo ispirazione dal concetto "gli opposti si attraggono", la palette di modelli che abbiamo disegnato, rappresenta un mix equilibrato di linee sfarzose razionalizzate e definizioni tecniche delicatamente sartoriali.

I materiali di cui si compone il nostro design, si uniscono in modo alle volte inaspettato ma sempre e comunque convincente.

GRVN è etica ed estetica come dichiarazione di stile.

Perché con i nostri "prodotti ottimisti", desideriamo comunicare l'importanza di circondarsi e di convivere con oggetti che raccontino la bellezza di ogni fase che ha determinato la loro nascita.

GRVN  
WE DESIGN, WE CREATE, YOU ENJOY  
AND NOW, "RELAX & SIT IT EASY..."

#### INSPIRED, CREATIVE, FUNCTIONAL

GRVN est une ligne émergente de canapés contemporains. Spin-off industriel de GARAVINI HOME, une industrie générative italienne, spécialisée dans le prototypage élevé et la production de meubles rembourrés pour certaines des chaînes de distribution européennes les plus connues.

Fort des nombreuses années d'expérience du Groupe GARAVINI HOME, GRVN peut compter sur une supply chain très méthodologisée.

Garavini Vanni, d'où l'acronyme GRVN, a su valoriser et optimiser de manière circulaire tous les processus de production : du prototypage intégré, à l'approvisionnement extensif, jusqu'à la production généralisée et la distribution orientée, en passant par les canaux de vente avec une approche dédiée aux différents types de Clients B2B. La philosophie du Brando GRVN trouve ses racines dans l'idée de vivre de manière de plus en plus consciente, heureusement conscient d'être un ensemble de contradictions dans un monde en évolution rapide.

L'analyse constante des nouveaux comportements et des nouvelles habitudes des espaces de vie participe activement à notre « mélange stylistique ».

Pour mettre l'accent sur le bien-être partagé, nous pensons qu'il faut aller vers de nouvelles formes d'« optimisme produit », sensibilisant le Client à une connaissance approfondie du secteur dans lequel nous opérons.

S'inspirant du concept « les contraires s'attirent », la palette de motifs que nous avons conçue représente un mélange équilibré de lignes somptueuses épurées et de définitions techniques délicatement adaptées.

Les matériaux qui composent notre design s'assemblent de manière parfois inattendue mais toujours convaincante.

GRVN est l'éthique et l'esthétique comme déclaration de style.

Car avec nos « produits optimistes », nous souhaitons communiquer l'importance de s'entourer et de vivre avec des objets qui racontent la beauté de chaque phase qui a déterminé leur naissance.

GRVN  
WE DESIGN, WE CREATE, YOU ENJOY  
ET MAINTENANT, "RELAX & SIT IT EASY..."



relax & sit it easy



Garavini S.r.l.  
info@grvnhome.com  
www.grvnhome.com  
Forlì . Italy . Europe

# GRVN

## Sofas

---



**PENTHOUSE**  
358



**ORCHESTRA**  
362



**SPACE**  
401



**FOUR SEASONS**  
402



**CITIZEN**  
403



**LIFESTYLE**  
404



**UPTOWN**  
412



**STUDIO**  
415

collection



PENTHOUSE  
358



AVAILABLE IN BOTH LEATHER AND FABRIC.  
*Not removable cover.*  
FRAME: plywood with fir details. SUSPENSION: seat in reinforced elastic webbing. SITTING CUSHIONS: in polyurethane 35 Kg/m<sup>3</sup> covered with wadding.  
BACK CUSHIONS: feather blend.  
FEET: wood.

DISPONIBILE SIA IN PELLE CHE IN TESSUTO.  
*Prodotto non sfoderabile.*  
TELAIO: multistrato con particolari in abete. SOSPENSIONI: sedute in cinghie elastiche rinforzate. CUSCINI SEDUTA: in poliuretano 35 Kg/m<sup>3</sup> rivestiti in ovatta. CUSCINI SCHIENALE: in misto piuma.  
PIEDI: in legno.



PENTHOUSE . 358

002



004



543



542



014



013



016



015



140

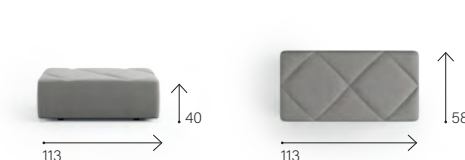

506

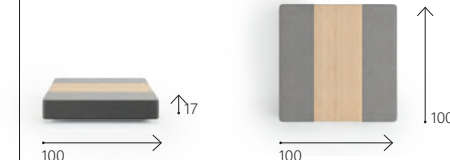

013 + 542

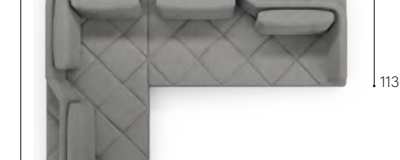

PENTHOUSE . 358







ORCHESTRA  
362



AVAILABLE IN BOTH LEATHER AND FABRIC.  
 STRUCTURE: not removable cover. BACKREST  
 CUSHIONS: removable cover.  
 FRAME: plywood with fir details.  
 SUSPENSION: seat in reinforced elastic webbing  
 SITTING CUSHIONS: in polyurethane 35 Kg/m<sup>3</sup> covered  
 with wadding.  
 BACK CUSHIONS: Removable in polyurethane 25 Kg/m<sup>3</sup>  
 covered with wadding.  
 FEET: plastic Non-Slip.

DISPONIBILE SIA IN PELLE CHE IN TESSUTO.  
 STRUTTURA: non sfoderabile. CUSCINI SCHIENALE:  
 sfoderabili.  
 TELAIO: multistrato con particolari in abete. SOSPENSIONI:  
 sedute in cinghie elastiche rinforzate. CUSCINI SEDUTA: in  
 poliuretano 35 Kg/m<sup>3</sup> rivestiti in ovatta. CUSCINI  
 SCHIENALE: sfoderabili in poliuretano 25 Kg/m<sup>3</sup> rivestiti in  
 ovatta.  
 PIEDI: antiscivolo in plastica.



ORCHESTRA . 362

013

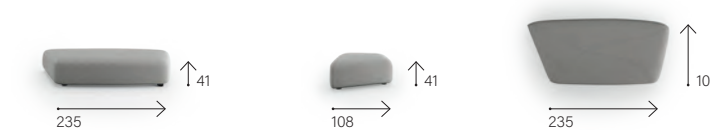

014

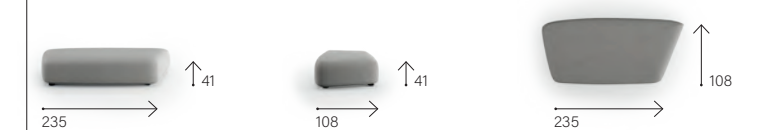

022



021

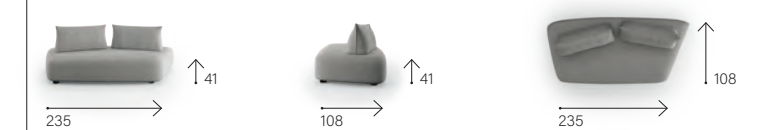
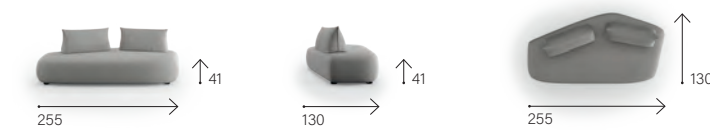
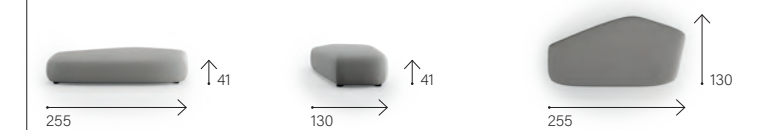

021 + 022 + 2x237

014 + 022 + 2x237

014 + 021 + 2x237

013 + 021 + 2x237

014 + 013 + 2x237

014 + 013 + 4x237



237

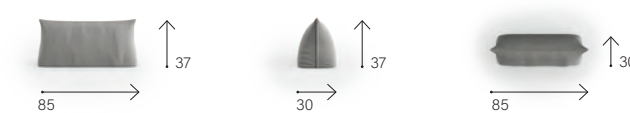

ORCHESTRA . 362





SPACE  
401



AVAILABLE IN BOTH LEATHER AND FABRIC.

*Not removable cover.*

FRAME: plywood and iron details.  
 SUSPENSION: seat in reinforced elastic webbing.  
 SITTING CUSHIONS: in polyurethane 35 Kg/m<sup>3</sup> covered with wadding.  
 BACK CUSHIONS: in polyurethane covered with wadding.  
 ARMREST: in polyurethane 25-21 Kg/m<sup>3</sup> covered with wadding.  
 FEET: painted metal.

DISPONIBILE SIA IN PELLE CHE IN TESSUTO.

*Prodotto non sfoderabile.*

TELAIO: dettagli in multistrato e ferro.  
 SOSPENSIONI: sedute in cinghie elastiche rinforzate.  
 CUSCINI SEDUTA: in poliuretano 35 Kg/m<sup>3</sup> rivestiti in ovatta.  
 CUSCINI SCHIENALE: in poliuretano rivestito in ovatta.  
 BRACCIOLO: in poliuretano 25-21 Kg/m<sup>3</sup> rivestito in ovatta.  
 PIEDI: in metallo verniciato.



001



002

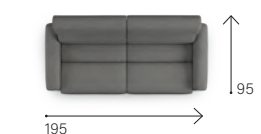

003



004



006

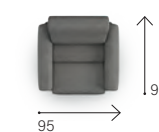

SPACE . 401

SPACE . 401





LVE DESIGN INDUSTRY

## FOUR SEASONS 402



AVAILABLE IN BOTH LEATHER AND FABRIC.  
 STRUCTURE: not removable cover. CUSHIONS:  
 removable cover  
 FRAME: plywood with fir details.  
 SUSPENSION: seat in reinforced elastic webbing.  
 SITTING CUSHIONS: in polyurethane 30 Kg/m<sup>3</sup>  
 covered with wadding.  
 BACK CUSHIONS: in polyurethane 25 Kg/m<sup>3</sup>  
 covered with wadding.  
 ARMREST: in polyurethane covered with wadding.  
 FEET: painted metal.

DISPONIBILE SIA IN PELLE CHE IN TESSUTO.  
 STRUTTURA: non sfoderabile. CUSCINI: sfoderabili.  
 TELAIO: multistrato con dettagli in abete.  
 SOSPENSIONI: sedute in cinghie elastiche rinforzate.  
 CUSCINI SEDUTA: in poliuretano 30 Kg/m<sup>3</sup> rivestiti in ovatta.  
 CUSCINI SCHIENALE: in poliuretano rivestito in ovatta.  
 BRACCIOLO: in poliuretano 25 Kg/m<sup>3</sup> rivestito in ovatta.  
 PIEDI: in metallo verniciato.



575



576



001



002

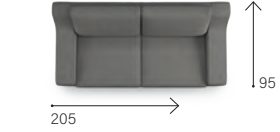

003



006

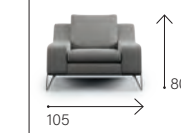

142

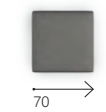

140

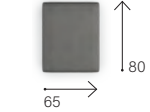

# FOUR SEASONS . 402

FOUR SEASONS . 402





CITIZEN  
403



AVAILABLE IN BOTH LEATHER AND FABRIC.  
 STRUCTURE: not removable cover. CUSHIONS: removable cover (backrest, seat, armrest)  
 FRAME: iron and plywood.  
 SUSPENSION: seat in reinforced elastic webbing. SITTING CUSHIONS: in polyurethane 35 Kg/m<sup>3</sup> covered with wadding.  
 BACK CUSHIONS: in polyurethane 21 Kg/m<sup>3</sup> covered with wadding.  
 ARMREST: in polyurethane 25 Kg/m<sup>3</sup> covered with wadding.  
 FEET: painted metal.

DISPONIBILE SIA IN PELLE CHE IN TESSUTO.  
 STRUTTURA: non sfoderabile. CUSCINI: sfoderabili (schienale, seduta, bracciolo)  
 TELAIO: ferro e multistrato.  
 SOSPENSIONI: sedute in cinghie elastiche rinforzate. CUSCINI SEDUTA: in poliuretano 35 Kg/m<sup>3</sup> rivestiti in ovatta. CUSCINI SCHIENALE: in poliuretano 21 Kg/m<sup>3</sup> rivestiti in ovatta. BRACCIOLO: in poliuretano 25 Kg/m<sup>3</sup> rivestito in ovatta. PIEDI: in metallo verniciato.



001

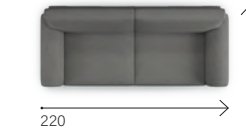

002

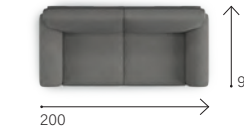

003

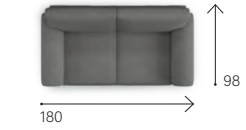

004

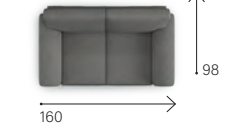

006

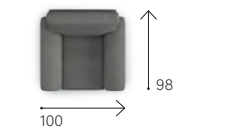

CITIZEN . 403

CITIZEN . 403







## LIFESTYLE 404



AVAILABLE IN BOTH LEATHER AND FABRIC.

Not removable cover.

FRAME: Plywood.

SUSPENSION: seat in reinforced elastic webbing. SITTING CUSHIONS: in polyurethane 35 Kg/m<sup>3</sup> covered with wadding.

BACK CUSHIONS: in polyurethane 25 Kg/m<sup>3</sup> covered with wadding.

ARMREST: in polyurethane 25 Kg/m<sup>3</sup> covered with wadding.

FEET: painted metal.

*The measurements may vary by a maximum of 2/3 cm.*

DISPONIBILE SIA IN PELLE CHE IN TESSUTO.

Prodotto non sfoderabile.

TELAIO: multistrato.

SOSPENSIONI: sedute in cinghie elastiche rinforzate. CUSCINI SEDUTA: in poliuretano 35 Kg/m<sup>3</sup> rivestiti in ovatta. CUSCINI SCHIENALE: in poliuretano 25 Kg/m<sup>3</sup> rivestiti in ovatta.

BRACCIOLO: in poliuretano 25 Kg/m<sup>3</sup> rivestiti in ovatta. PIEDI: in metallo verniciato.

*Le misure potrebbero variare di 2/3 cm massimo.*



# LIFESTYLE . 404

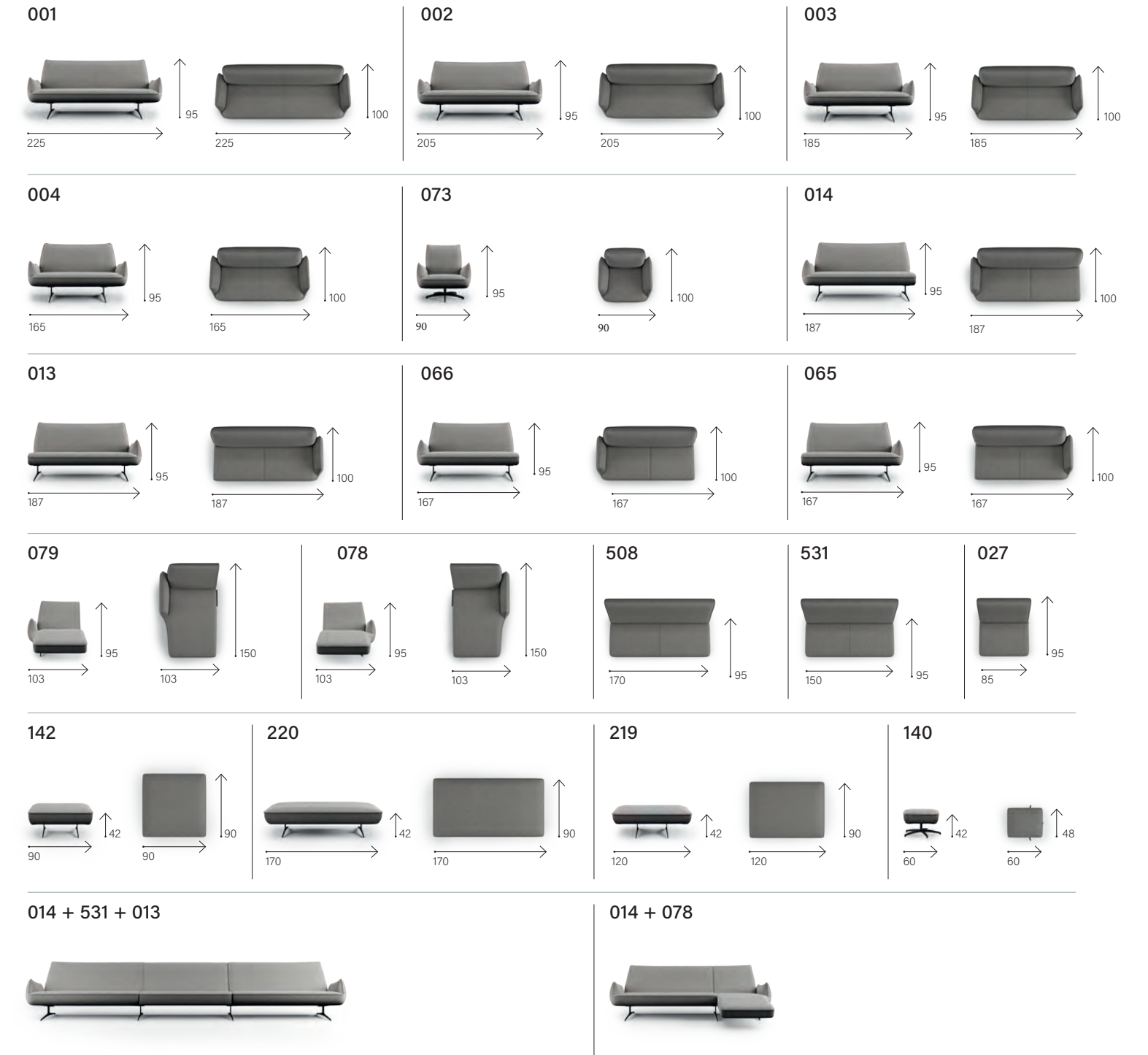

**PLEASE NOTE**

In case of compositions, for Model LIFESTYLE, in the central part of the union of the two elements (for example 3 seater on the left side + central element + 3 seater on the right side, and/or 3 seater on the side + chaise longue), there will be a single foot that will connect and support the two elements.

**NOTA BENE**

Nel caso di composizioni, nella parte centrale dell'unione dei due elementi (ad esempio 3 posti laterale SX + centrale medio + 3 posti laterale DX, COME IN FOTO e/o 3 posti laterale SX + chaise longue DX), verrà inserito/montato un unico piede che collegherà e supporterà i due elementi.

LIFESTYLE . 404





LVE DESIGN INDUSTRY

**UPTOWN  
412**



AVAILABLE ONLY IN FABRIC.  
Entirely removable cover.

FRAME: plywood with fir details.  
SUSPENSION: mattress springs plus straps.  
SITTING CUSHIONS: in polyurethane 35-40 Kg/m<sup>3</sup> covered with wadding.

BACK CUSHIONS: removable curved designed, in polyurethane 25 Kg/m<sup>3</sup> covered with wadding.  
FEET: painted metal.

DISPONIBILE SOLO IN TESSUTO.  
Prodotto sfoderabile.

TELAIO: multistrato con particolari in abete.  
SOSPENSIONI: molle da materasso più cinghie.  
CUSCINI SEDUTA: in poliuretano 35-40 Kg/m<sup>3</sup> rivestiti in ovatta.  
CUSCINI SCHIENALE: sfoderabili dal design curvo, in poliuretano 25 Kg/m<sup>3</sup> rivestiti in ovatta.  
PIEDI: in metallo verniciato.



UPTOWN . 412

595

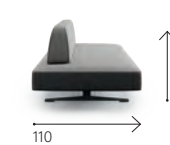

597



599

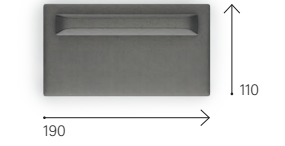

601

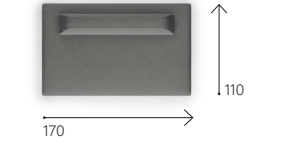
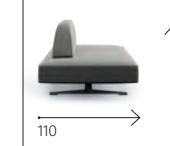

021

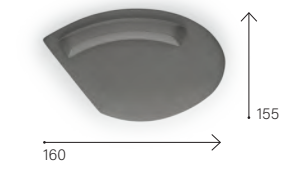

022

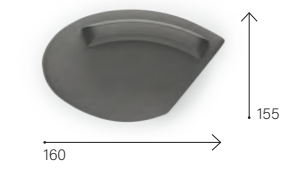

142

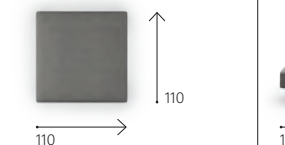

140

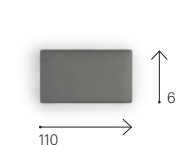
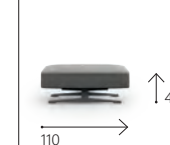

501

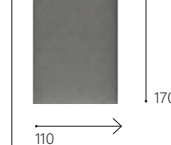

021 + 022



599 + 021



022 + 599 + 021

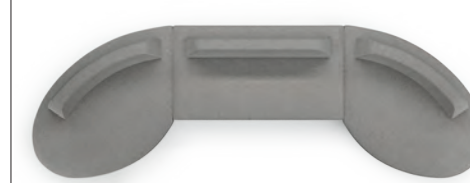

UPTOWN . 412





WE DESIGN INDUSTRY

STUDIO  
415



AVAILABLE IN BOTH LEATHER AND FABRIC.  
Not removable cover.  
FRAME: plywood with fir details. SUSPENSION:  
seat in reinforced elastic webbing. SITTING  
CUSHIONS: in polyurethane 35 Kg/m<sup>3</sup> covered  
with polyurethane 25 Kg/m<sup>3</sup>.  
BACK CUSHIONS: in polyurethane 25 Kg/m<sup>3</sup>  
covered with polyurethane 25 Kg/m<sup>3</sup>. ARMREST:  
in polyurethane 30 Kg/m<sup>3</sup>.  
FEET: wood.

DISPONIBILE SIA IN PELLE CHE IN TESSUTO.  
Prodotto non sfoderabile.  
TELAIO: multistrato con dettagli in abete. SOSPENSIONI:  
sedute in cinghie elastiche rinforzate. CUSCINI SEDUTA:  
in poliuretano 35 Kg/m<sup>3</sup> rivestiti con poliuretano 25 Kg/m<sup>3</sup>.  
CUSCINI SCHIENALE: in poliuretano 25 Kg/m<sup>3</sup> rivestiti in  
poliuretano 25 Kg/m<sup>3</sup>.  
BRACCIOLO: in poliuretano 30 Kg/m<sup>3</sup>.  
PIEDI: in legno.

001

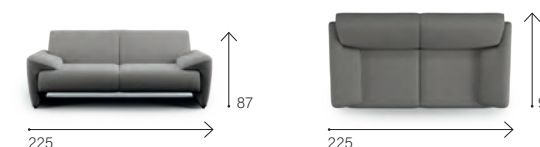

002

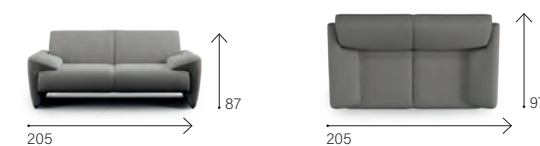

003

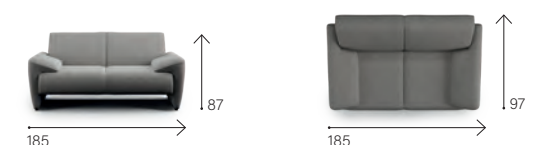

STUDIO , 415

STUDIO . 415





*accessories*

*accessori*

*accessoires*

*Pouffes and cushions are available for both the GARAVINI HOME and the GRVN collections.*

*I pouf e i cuscini sono disponibili sia per la collezione GARAVINI HOME che per la collezione GRVN.*

*Les poufs et coussins sont disponibles aussi bien pour la collection GARAVINI HOME que pour la collection GRVN.*

*acesories*

collection



Pouf



BEAT  
504



BLUES  
501



CHORUS  
503



SOUND  
502

Accessories



DECORATIVE  
CUSHIONS  
109





## POUF BEAT 504

Prodotto non sfoderabile.  
Disponibile in pelle e in tessuto.

Multistrato imbottito con poliuretano espanso indeformabile 30 kg/m<sup>3</sup> ricoperto da una fodera protettiva in tessuto.  
**PIEDI:** antiscivolo in plastica.

Not removable cover.  
Available in both leather and fabric.

Plywood padded with non-deformable polyurethane foam 30 kg/m<sup>3</sup> covered with a protective fabric lining.  
**FEET:** plastic non-slip.

DISEGNI IN SCALA 1:8 - MISURE ESPRESSE IN CM/POLLICI



143

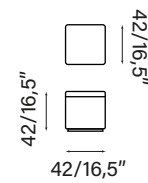

280

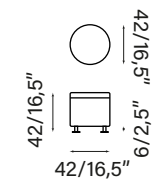
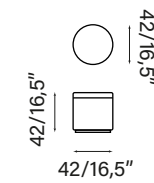
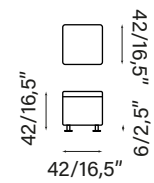

## POUF BEAT 504



## POUF BLUES 501

Prodotto non sfoderabile.  
Disponibile in pelle e in tessuto.

Multistrato imbottito con poliuretano espanso indeformabile 30 kg/m<sup>3</sup> ricoperto da una fodera protettiva in tessuto.  
**PIEDI:** antiscivolo in plastica.

Not removable cover.  
Available in both leather and fabric.

Plywood padded with non-deformable polyurethane foam 30 kg/m<sup>3</sup> covered with a protective fabric lining.  
**FEET:** plastic non-slip.

DISEGNI IN SCALA 1:8 - MISURE ESPRESSE IN CM/POLLICI

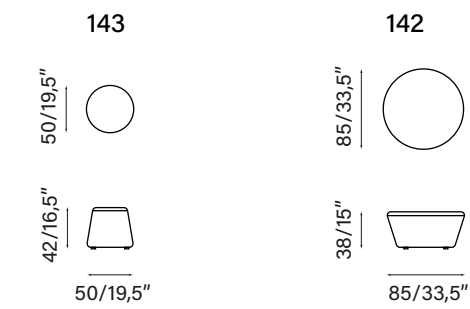

## POUF BLUES 501



## POUF CHORUS 503

Prodotto non sfoderabile.  
Disponibile in pelle e in tessuto.

Multistrato imbottito con poliuretano espanso indeformabile 30 kg/m<sup>3</sup> ricoperto da una fodera protettiva in tessuto.

**PIEDI:** antiscivolo in plastica.

Not removable cover.  
Available in both leather and fabric.

Plywood padded with non-deformable polyurethane foam 30 kg/m<sup>3</sup> covered with a protective fabric lining.

**FEET:** plastic non-slip.

DISEGNI IN SCALA 1:8 - MISURE ESPRESSE IN CM/POLLICI

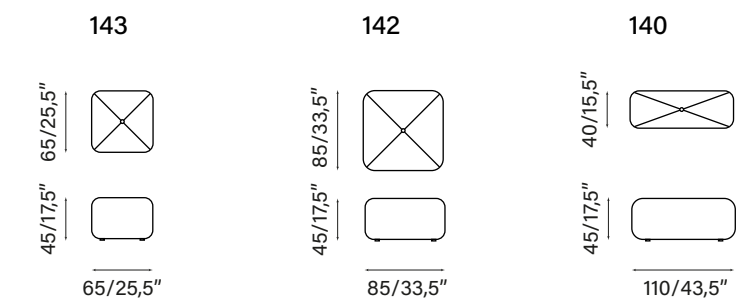

## POUF CHORUS 503

# CHORUS 503





## POUF SOUND 502

Prodotto parzialmente sfoderabile. Base fissa, cuscino sfoderabile.  
Disponibile in pelle e in tessuto.

Multistrato imbottito con poliuretano espanso indeformabile 30 kg/m<sup>3</sup> ricoperto da una fodera protettiva in tessuto.  
**PIEDI:** antiscivolo in plastica.

Partially removable product. Fixed base, removable cushion cover.  
Available in both leather and fabric.

Plywood padded with non-deformable polyurethane foam 30 kg/m<sup>3</sup> covered with a protective fabric lining.  
**FEET:** plastic non-slip.

DISEGNI IN SCALA 1:8 - MISURE ESPRESSE IN CM/POLLICI

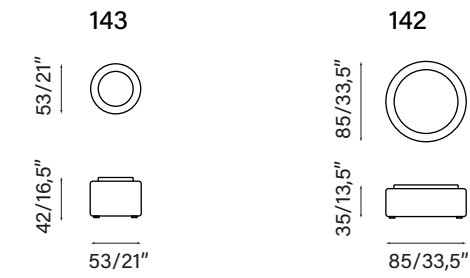

## POUF SOUND 502

# SOUND 502





## DECORATIVE CUSHIONS 109

Nel caso di ordine di un set di divani in pelle o anche di un solo divano e/o poltrona in pelle, nella stessa tipologia e colore, possono essere richiesti anche cuscini ornamentali in coordinato.

Prodotto interamente sfoderabile.  
Disponibile solo in tessuto.

**FORMA:** lombare o quadrato.  
**IMBOTTITURA INTERNA:** sfoderabili in poliuretano 25 kg/m<sup>3</sup> rivestito in ovatta.  
**FINITURA:** saponetta, fascia o a becco d'oca.

In case of order of a set of leather sofas or even a single leather sofa and/or armchair, in the same type and colour, can also be requested coordinated ornamental cushions.

Entirely removable cover.  
Available only in fabric.

**SHAPE:** lumbar or squared.  
**INSIDE PADDING:** removable covers made of 25 kg/m<sup>3</sup> polyurethane covered with wadding.  
**FINISH:** soap pad, band or goose beak.

DISEGNI IN SCALA 1:8 - MISURE ESPRESSE IN CM/POLLICI

901

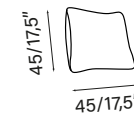

911

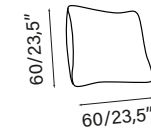

921

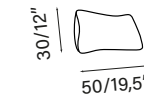

931



934

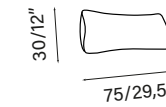

902

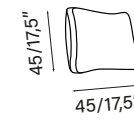

912

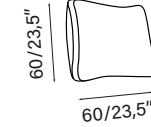

922

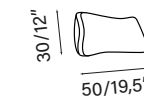

932

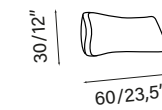

935

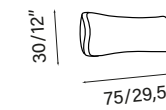

900

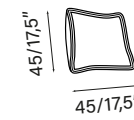

910

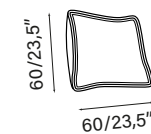

920

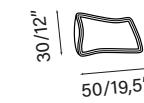

930

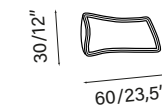

933

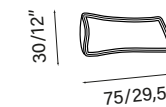

## DECORATIVE CUSHIONS 109

# DECORATIVE CUSHIONS 109

